



FW253 Integrated Under Counter Larder Fridge With Ice Box

Manual for Installation, Use and Maintenance

Contents page

page 4	Important
page 6	General warnings
page 8	Important
page 9	Before first use
page 10	Setting the temperature
page 12	Use
page 13	Ice box
page 14	Storage frozen food products
page 15	Care and cleaning
page 16	Defrosting the fridge
page 17	Changing the light bulb Troubleshooting
page 19	Installation Contents and Tools Required
page 20	Installation
page 25	Reversing the door
page 26	Electrical information

Important

The CDA Group Ltd cannot be held responsible for injuries or losses caused by incorrect use or installation of this product. Please note that CDA reserve the right to invalidate the guarantee supplied with this product following incorrect installation or misuse of the appliance.

This appliance is not designed to be used by people (including children) with reduced physical, sensorial or mental capacity, or who lack experience or knowledge about it, unless they have had supervision or instructions on how to use the appliance by someone who is responsible for their safety.

Under no circumstances should any external covers be removed for servicing or maintenance except by suitably qualified personnel.

Appliance information:

Please enter the details on the appliance rating plate below for reference, to assist CDA Customer Care in the event of a fault with your appliance and to register your appliance for guarantee purposes.

Appliance Model	
Serial Number	

CE Declarations of Conformity:

This appliance has been designed, constructed and marketed in compliance with safety requirements of EEC Directive 2006/95/EEC

(Low voltage) and requirements of EMC Directive 2004/108/EEC.

This appliance has been manufactured to the strictest standards and complies with all applicable legislation, including Electrical safety (LVD) and Electromagnetic interference compatibility (EMC). Parts intended to come into contact with food conform to EEC/89/109.4

IMPORTANT INFORMATION FOR CORRECT DISPOSAL OF THE PRODUCT IN ACCORDANCE WITH EC DIRECTIVE 2002/96/EC.

At the end of its working life, the product must not be disposed of as urban waste. It must be taken to a special local authority differentiated waste collection centre or to a dealer providing this service.

Disposing of a household appliance separately avoids possible negative consequences for the environment and health deriving from inappropriate disposal and enables the constituent materials to be recovered to obtain significant savings in energy and resources. As a reminder of the need to dispose of household appliances separately, the product is marked with a crossed-out wheeled dustbin. 

General warnings

WARNING: Keep ventilation openings, in the appliance enclosure or in the built-in structure, clear of obstruction.

WARNING: Do not use mechanical devices or other means to accelerate the defrosting process, other than those recommended by the manufacturer.

WARNING: Do not use electrical appliances inside the food storage compartments of the appliance, unless they are of the type recommended by the manufacturer.

WARNING: Do not damage the refrigerant circuit.

WARNING: To avoid a hazard due to the instability of the appliance, it must be fixed in accordance with the instructions.

- If your appliance uses R600a as a refrigerant
 - Take care during transport and installation to prevent your appliance's cooler elements from being damaged. R660a is an environmentally friendly, natural gas. As it is flammable, keep away from naked flames and heat sources.
- Do not store explosive substances such as aerosol cans with a flammable propellant in this appliance.
- This appliance is not intended for commercial use.
- If the socket does not match the refrigerator plug, it must be replaced by the manufacturer, its service agent or similar qualified

persons in order to avoid a hazard.

- This appliance is not intended for use by persons (including children) with reduced physical, sensory or mental capabilities, or lack of experience and knowledge, unless they have been given supervision or instruction concerning use of the appliance by a person responsible for their safety. Children should be supervised to ensure that they do not play with the appliance.
- A specially grounded plug has been connected to the power cable of your refrigerator. This plug should be used with a specially grounded socket of 13 amps. If there is no such socket in your house, please have it installed by an authorized electrician.
- This appliance can be used by children aged from 8 years and above and persons with reduced physical, sensory or mental capabilities or lack of experience and knowledge if they have been given supervision or instruction concerning use of the appliance in a safe way and understand the hazard involved.
- If the supply cord is damaged, it must be replaced by the manufacturer, its service agent or similar qualified persons in order to avoid a hazard.

Important

Never store inflammable or explosive items and strong corrosive acids or alkalis in the appliance.

This is a household appliance, which is produced in accordance with the national standard. It is intended for food storage only, not for storage of blood, medicine and biological products.

To prevent risk of fire, keep the appliance away from petrol or any other inflammables.

To prevent risk of electromagnetic interference or other accidents, do not place a microwave oven on top of the refrigerator or use any electric appliance inside the refrigerator.

Do not allow children to play with or near the appliance.

The internal surface of freezer compartment is very cold when the appliance is running. Do not touch the surface especially with wet hands.

Do not splash water onto the appliance. Keep it away from places of high humidity that may have adverse effect on the electric insulation performance.

Please remove the door, door seal and shelves before disposal of the old appliance and put them away in a safe place to prevent children from being entrapped.

Before first use

You must allow the fridge to settle for at least twenty four hours prior to switching the power on.

It is recommended that you clean the interior of the appliance prior to first use, using a solution of bicarbonate of soda and warm water and then thoroughly drying the interior.

The fridge may have an odour to it at first use. This will disappear as the appliance cools.

Please note:

- The appliance will work continuously until it comes down to the correct temperature.
- It is recommended that the appliance be allowed to run empty for 24 hours after first switch on, without opening the door. If this is not possible, do not overload the appliance to allow it to reach temperature.
- If the appliance is switched off, you should allow five minutes before switching it on again to prevent unnecessary damage to the compressor.
- Never store inflammable or explosive items and strong corrosive acids or alkalis in the appliance.

Setting the temperature

You must allow the fridge to settle for at least twenty four hours prior to switching the power on.

The thermostat automatically regulates the inside temperature of the appliance.

To adjust the temperature, turn the thermostat control knob clockwise (from off) to the required level. The temperature becomes colder the higher the number on the thermostat control.

For short term storage of food in the ice box, set the thermostat between 1-3.

For long term storage of food in the ice box, set the thermostat between 3-4.

Please note:

- Turning the thermostat control knob anticlockwise beyond position 1 will switch the appliance off.
- Factors including the ambient temperature, temperature of freshly stored food and frequency of door opening will affect the temperature in the appliance. The temperature should be adjusted accordingly.

Use

Fridge

- Never put liquids in the refrigerator uncovered.
- Never put hot foods in the refrigerator. Warm food should be allowed to cool to room temperature before being put into the refrigerator.
- Nothing should rest against the rear wall of the refrigerator, as this will cause frost and possible condensation problems which will be difficult to remove.
- Make sure food is clean and any extra water is wiped away before putting into the fridge.
- Wrap or cover food before putting into the fridge. This will help prevent the loss of moisture, keep food fresh and avoid unpleasant odours.
- Sort foods prior to storing. Any foods to be used soon should be stored at the front of the shelf to prevent deterioration caused by the door being open for prolonged periods.
- Do not overfill the fridge. There should be sufficient space between the foods to allow the cool air to circulate.
- Thawing frozen foods in the fridge compartment will help to keep the temperature low and save energy.
- Only open the door for as long as is necessary. Leaving the door open for long periods will affect the temperature inside the appliance and waste energy.
- Ensure all compartments are fully closed after use.

Ice box

The ice box door should be kept closed to prevent the contents of the ice-box defrosting, heavy build up of frost in the ice-box and excessive unnecessary use of energy.

Freezing fresh food

- Set the thermostat knob to 5.
- Wrap and seal the food in aluminium foil, cling film, watertight plastic bags, polythene containers with lids or special freezer containers.
- Arrange the food to be frozen centrally in the freezer compartment.
- Avoid contact between already frozen food and food that has yet to be frozen (approx. 20 mm distance).
- After 24 hours turn the thermostat knob back to the normal position.
- If the ice box door is not closed correctly, a red indicator will show in the ice box door handle.

Please note: The amount of fresh food that can be frozen within 24 hours is shown on the rating plate as freezing capacity. For optimum performance to reach maximum freezing capacity, set the thermostat knob position as '4'.

The temperature of the ice box will reach at least -18°C

Ice box

Storing frozen food products

- When shopping, leave frozen food purchases until last and transport products in a thermally insulated cool bag.
- Once at home, place the frozen foods immediately in the ice box. Ensure that the packaging is not damaged.
- If the package is swollen or has damp patches, it may not have been stored under optimal conditions and defrosting may have already begun.
- If food has defrosted even partially, do not re-freeze it. Consume within 24 hours.
- Avoid subjecting foods to temperature variations. Observe the “best before” date on the package.
- Always observe the storage information on the package.

Care and cleaning

Always disconnect the appliance from the power supply before any cleaning or maintenance.

The fridge sections should be cleaned using a solution of bicarbonate of soda and lukewarm water. Do not use abrasive products or detergents. After washing, rinse and dry thoroughly.

Clean the shelves and balconies separately by hand with soap and water. Do not put them in the dishwasher.

The water drain hole at the back of the fridge compartment and the evaporating tray should be cleaned periodically to prevent the defrosted water from collecting inside the fridge compartment. The drain plug can be used to clean the drain hole.

Once cleaning is complete, then reconnect the power.

- Keep the door gasket clean. If damaged, the gasket should be replaced.
- If the appliance is not used for prolonged periods of time, unplug and clean the appliance. The door should be left slightly open to prevent the formation of mildew and smell.

Defrosting the fridge

The fridge is self-defrosting. Any water created will run out of the fridge through the channel at the back of the fridge.

It is important to keep the channel clear at all times. The defrosted water is collected in the evaporating tray at the back of the appliance.

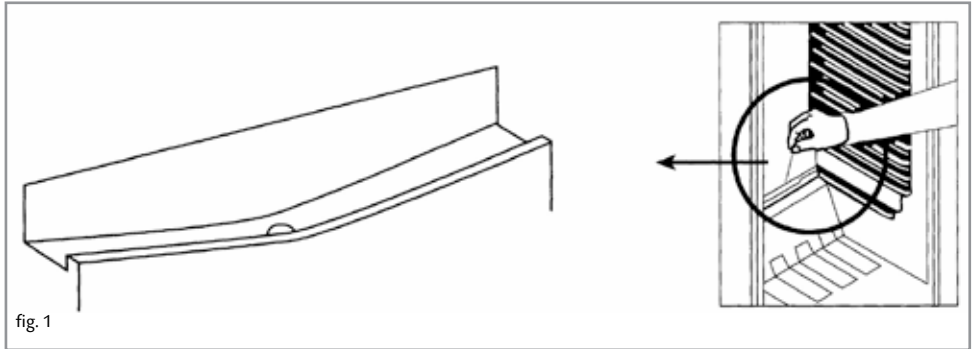

Defrosting the ice-box

The ice box should be defrosted regularly to ensure the most efficient running, at a minimum of once every six months.

- Do not use heaters or defrosting sprays in this appliance.
- Never use any metallic or sharp objects to remove the ice as this could damage the lining.
- To speed up the process, put a bowl of warm water in the base of the ice-box compartment.
- Once defrosting is complete, dry the inside of the ice-box with a sponge or clean cloth.
- To bring the unit back to temperature more quickly set the thermostat to 5 after defrosting.

Changing the light bulb

Disconnect the appliance from the power.

- Carefully remove the light cover by pushing in the lever at the back of the cover, and then pulling the cover down.
- Unscrew the light bulb to remove it and replace with a new bulb (max 15W).
- Replace the light cover and reconnect the power after five minutes' delay as explained on page 9.

Troubleshooting

If you have any problems with your appliance, you should check the troubleshooting prior to calling CDA Customer Care to prevent unnecessary service calls and potential cost.

If the appliance is not working

- Check there is power to the appliance:
- The house fuses are intact and the fuse in the plug has not blown.
- The thermostat is not set to 0 (off position).
- The plug socket is functioning fine. To check this, plug another electrical appliance in to see if the socket is working.
- The temperature of the room is adequate (16°C or above).

The appliance is working, but not very well

- The appliance is not overloaded.
- The thermostat is set to an appropriate temperature.

Troubleshooting

- The door is closing properly.
- The cooling system at the rear of the appliance is clean and free of dust, and not touching the rear wall.
- There is enough ventilation at the side and rear walls.
- The temperature of the room is adequate (16°C or above).

The appliance is noisy

- The appliance is level and stable.
- The side and rear walls are clear, and there is nothing resting on the appliance.
- The cooling gas in the refrigerator will make a slight bubbling noise, even when the compressor is not running.

There is water in the lower part of the refrigerator compartment

- The drain hole in the channel at the back of the compartment is clear.

Installation

This appliance must never be installed close to heat sources i.e. heating elements, radiators, cookers or in damp places.

The appliance should be mounted on a piece of wood (for example a section of worktop or kitchen carcass) if a raised floor is to be fitted, if the kitchen floor is to be tiled after installation, or if the installation height of the appliance is greater than 850 mm.

Contents and Tools Required

Fig. 2 - Installation kit contents

1. Wood screw (17 pcs)
2. Decor door fixing bracket
3. Decor door base fixings (2 pcs)
4. Decorative cover
5. Screw
6. Top bracket

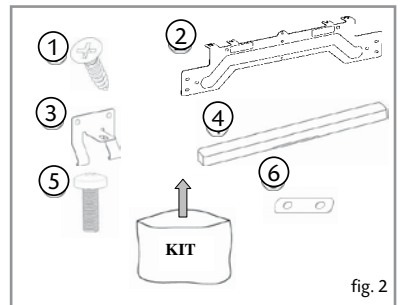

fig. 2

Fig. 3 - Tools required

7. Spirit level
8. Spanner
9. Setsquare
10. Flathead screwdriver

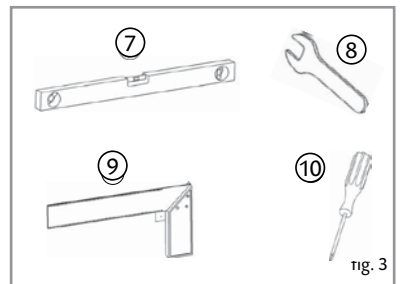

fig. 3

Installation

Fig. 4 - Dimensions of the appliance

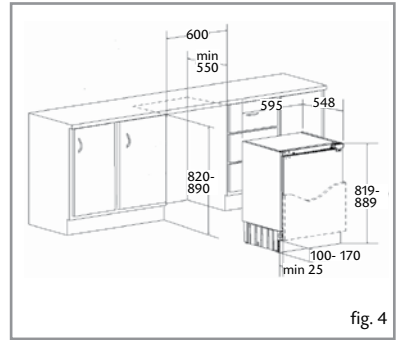

Fig. 5 - Fitting the worktop bracket

Remove the screw (5) on the top of the appliance, locate the top bracket(6) and fix the bracket with screw(5).

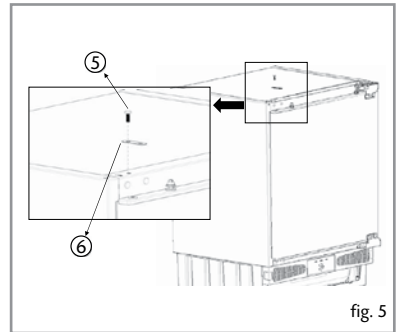
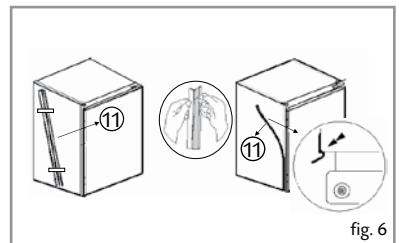

Fig.6 - Fitting the spacer piece

Take out the spacer piece (11) located on the side panel and remove the protective tape. Stick the spacer piece on the opposite side to the door hinges of the appliance.



Installation

Fig. 7 - Adjusting the appliance height

The height of the appliance can be adjusted by the help of adjustable feet to fit the furniture height. Use a spirit level to ensure the appliance is level.

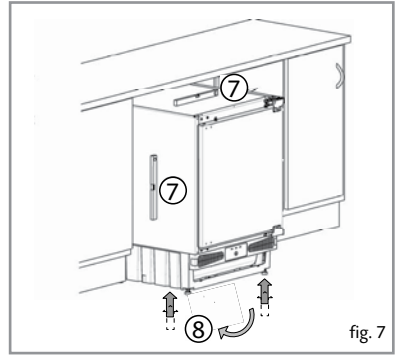

fig. 7

Fig. 8 - Aligning the appliance

Slide the appliance into the kitchen unit and align the hinge surface with front surface of the kitchen unit.

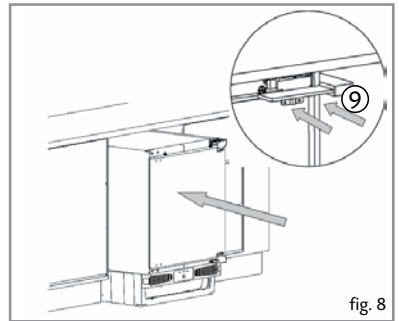

fig. 8

Fig. 9 - Fixing the appliance

Screw the hinges and metal bracket to the kitchen unit using screws (1)

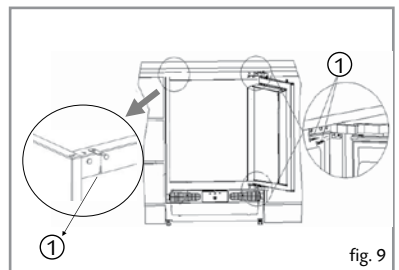

fig. 9

Installation

Fig. 10 - Fitting the decor door bracket

Unscrew and remove the nuts and washers from the appliance door. Place fixing bracket on the appliance door by inserting the holes to adjustment bolts.

Dimension B = Measure from the underside surface of kitchen unit to the bottom of fixing bracket.

Dimension C = Measure from the underside surface of kitchen unit to the top of next unit door.

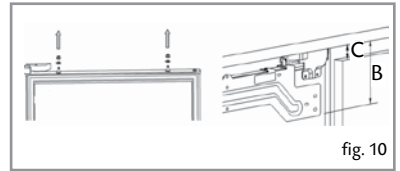
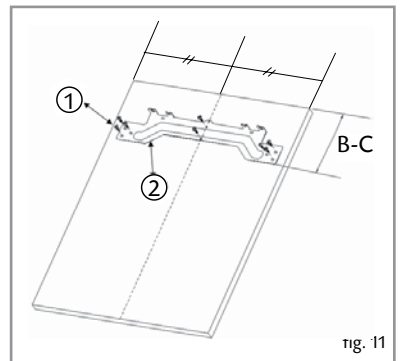

Fig. 11 - Fitting the decor door bracket

Substract C from B and put the fixing bracket (2) in place using this measurement for vertical position and place to the centre for horizontal position. Secure the fixing bracket (2) using screws(1).



Installation

Fig. 12 - Fitting the decor door

Place the decor door onto the appliance door by inserting adjustment bolts into the slots on the fixing bracket. Locate the washers and screw the nuts onto the adjustment bolts.

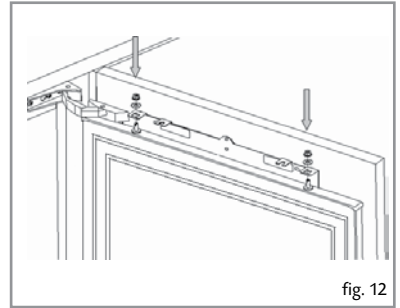

Fig. 13 - Aligning the decor door

Close the door and check the alignment with the other unit doors. Adjust the decor door by screwing or unscrewing the adjustment bolts for vertical adjustment and by the help of the slots on the fixing bracket for other directions. Lock the screws into place as shown in 10.2.

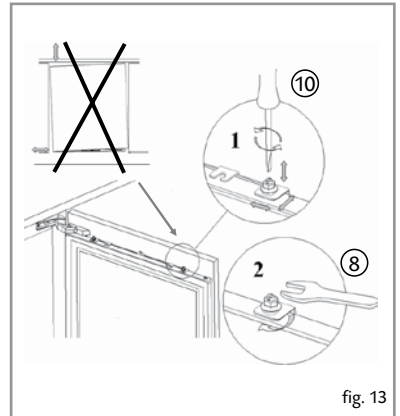
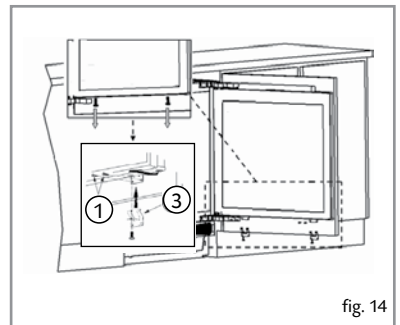

Fig. 14 - Fitting the decor door base fixings

With the appliance door open, remove the screws at the bottom of the appliance door. Locate the decor door base fixings (3) and screw the fixings to the appliance door and the decor door.



Installation

Fig. 15 - Fitting the decorative cover

Fit the decorative cover (4) on the decor door fixing bracket.

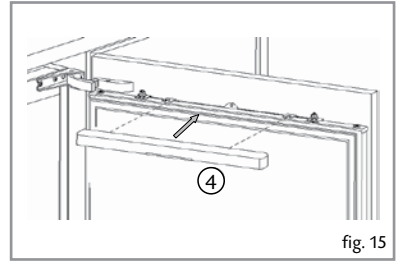
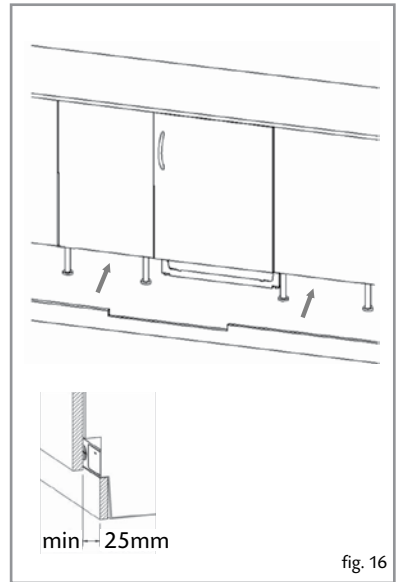

Fig. 16 - Fitting the plinth

Fit the plinth section, providing minimum 25 mm gap between the cabinet door and fix it. Never cover over the ventilation slots.

Once installed the plinth must not block the ventilation slots in the appliance.

This may require cutting the plinth down. Failure to ensure adequate ventilation may invalidate the warranty.



Reversing the door

It is possible to reverse the door on this appliance, if required. To do so, follow the steps below:

1. Open the door.
2. Loosen the hinge fixing screws (1) and remove the door.
3. Remove the door fixing screws (2).
4. Remove the cover caps (3).
5. Relocate the hinges as shown.
6. Refit the door to the hinges.

Do not turn the door upside down

7. Insert the cover caps (3) on the opposite side in the exposed holes.

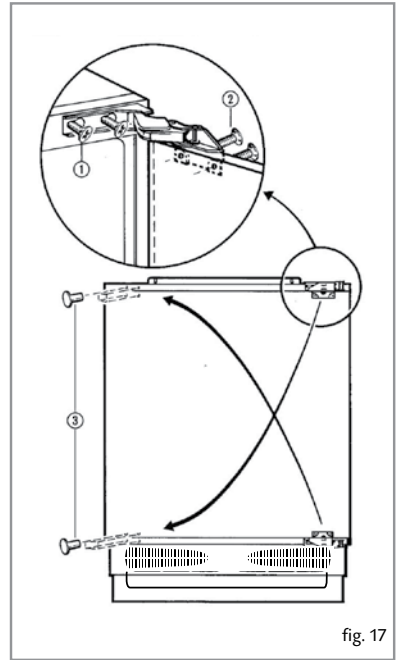

To reverse the ice box door (figure 18):

1. Open the ice box door
2. Remove the screw on the left side (1) to remove the catch.
3. Remove the screw on the bottom hinge support on the right side (2).
4. Fit the screw cover caps (supplied) in the exposed holes for the catch and bottom hinge support.

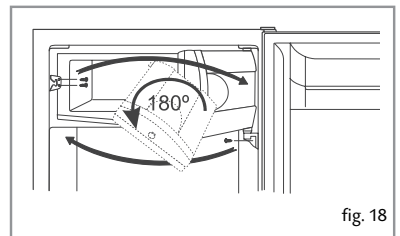

Reversing the door

5. Rotate the ice box door 180° and secure in position by fitting the bottom hinge on the left side using the screw removed in step 3.
6. Refit the door catch on the right side using the screw removed in step 2.

Electrical information

Warning! This appliance must be earthed.

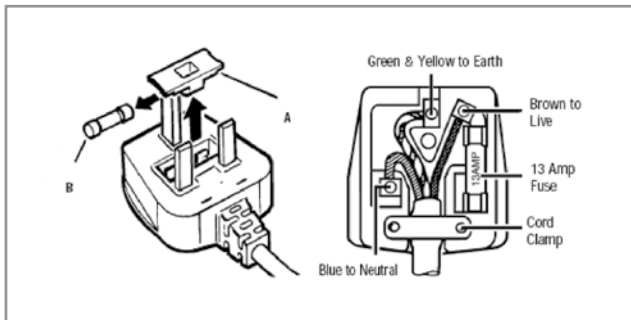

The mains lead of this appliance has been fitted with a BS 1363A 13 amp fused plug. To change a fuse in this type of plug, follow the steps below:

1. Remove the fuse cover and fuse.
2. Fit replacement 13A fuse, ASTA approved to BS 1362 type, into the fuse cover.
3. Replace fuse cover.

Important: Do not use the appliance without the fuse cover in position.

How to connect an alternative plug

If the fitted plug is not suitable for your socket outlet, then it should be cut off and disposed of safely to prevent the risk of electric shock. A suitable alternative plug of at least 13 Amp rating to BS 1363 should be used.

As the colours of the wires in the mains lead of this appliance may not correspond with the coloured markings identifying the terminals in your plug, proceed as follows:-

- The wire which is coloured **GREEN** and **YELLOW** must be connected to the terminal which is marked with letter **(E)** or by the **Earth** symbol  or coloured **GREEN** and **YELLOW**.
- The wire which is coloured **BLUE** must be connected to the terminal which is marked with the letter **(N)**, or coloured **BLACK**.
- The wire which is coloured **BROWN** must be connected to the terminal which is marked with the letter **(L)** or coloured **RED**.

If in doubt regarding the electrical connection of this appliance, consult a qualified electrician. Do not shorten the supply cable, the appliance may require removing for servicing.

N.B. Ensure that the plug socket is situated in an easily accessible place. If the power supply cord is damaged, it must be replaced by a CDA authorised agent.



Please contact our Customer Care Department, or for Service on the details below.

Customer Care Department • The CDA Group Ltd. • Harby Road • Langar • Nottinghamshire • NG13 9HY
T : 01949 862 012 F : 01949 862 003 E : service@cda.eu W : www.cda.eu